

# Alligator 0302 AS V4

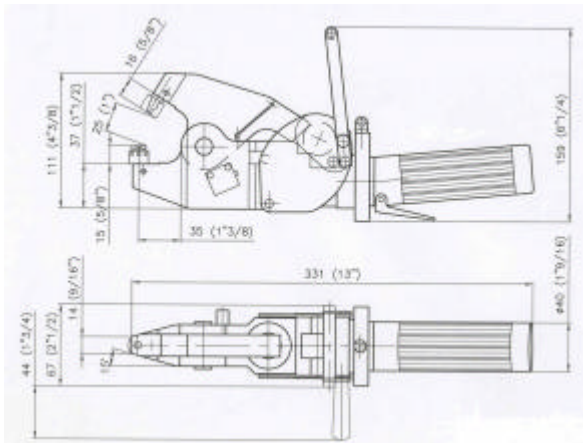

## Single-stroke clinching

In single-stroke clinching, the overlapping sheet material members are drawn into the die cavity. When the die side layer reaches the anvil at the bottom of the cavity, a clinch joint will be created through the squeezing between the punch and the anvil.

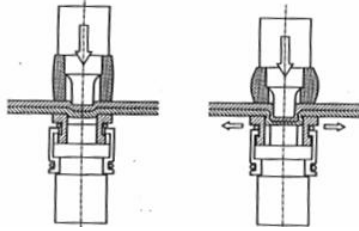

## Technical specifications

Workhead weight	3.7 kg	8.1 lbs
Drive pressure	6 bar	87 psi
Cycle time	0.6-0.9 s	
Maximum material thickness		
mild steel	3.0 mm	0.120"
aluminium	3.0 mm	0.120"

## Article number

**74 00006** Alligator 0302 AS V4, complete with workhead, handle, rotator, hose and booster, ready to be connected to a source of dry and clean compressed air at 6 bar, 87 psi

## Options

**92 70330** Upgrade to 3m, 10ft hose length

## Tool kits

To be selected from the table below

Mild steel , copper, materials with ductility >20%				
Total thickness	1.0-1.5 mm, 0.040-0.060"	1.5-2.0 mm 0.060-0.080"	2.0-2.5 mm 0.080-0.100"	2.5-3.0 mm 0.100-0.120"
4-bladed round	92 30700	92 30701	92 30702	72 00028
2-bladed round	92 30750	92 30751	92 30752	72 00031
Rectangular	92 30800	92 30801	92 30802	92 30803
Aluminum, brittle material				
4-bladed round	92 30705	92 30706	92 30707	72 00040
2-bladed round	92 30755	92 30756	92 30757	72 00043
Rectangular	92 30800	92 30801	92 30802	92 30803

**ATTEXOR Tools S.A.**  
 Chemin du Chêne 7  
 CH-1020 Renens/Lausanne  
 Switzerland  
 Phone: +41 21 691 13 80  
 Fax: +41 21 691 13 89  
 www.attexortools.com  
 info@attexortools.com

**ATTEXOR, Inc.**  
 90 Carando Drive  
 Springfield, MA 01104  
 United States  
 Phone: 413-746-0222  
 Fax: 413-746-6341  
 www.attexorinc.com  
 info@attexorinc.com

This document copyright  
 © 2005-2009 by  
 ATTEXOR Tools S.A.  
 All rights reserved  
 Printed matter No 55 02001  
 Nov-09

**Distributor**