

# Alligator 0302 AS V5

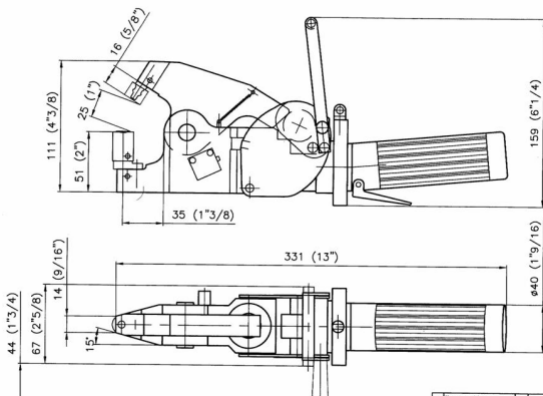

## Single-stroke clinching

In single-stroke clinching, the overlapping sheet material members are drawn into the die cavity. When the die side layer reaches the anvil at the bottom of the cavity, a clinch joint will be created through the squeezing between the punch and the anvil.

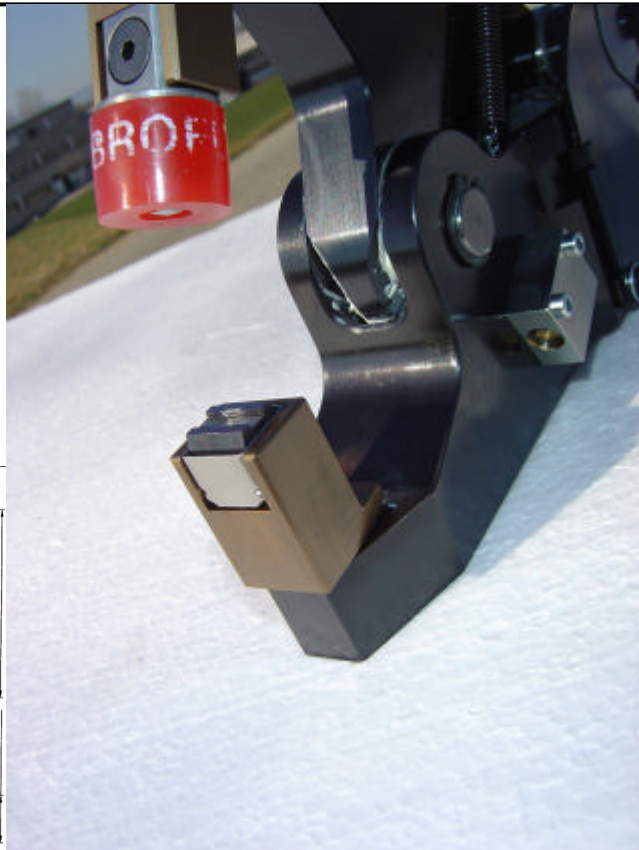
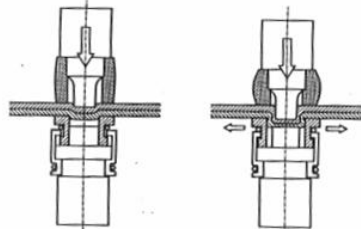

## Technical specifications

Workhead weight	3.7 kg	8.1 lbs
Drive pressure	6 bar	87 psi
Cycle time	0.6-0.9 s	
Maximum material thickness		
mild steel	3.0 mm	0.120"
aluminium	3.0 mm	0.120"

## Article number

**74 00007** Alligator 0302 AS V5, complete with workhead, handle, rotator, hose and booster, ready to be connected to a source of dry and clean compressed air at 6 bar, 87 psi

## Options

**92 70330** Upgrade to 3m, 10ft hose length

## Tool kits

To be selected from the table below

Mild steel , copper, materials with ductility >20%				
Total thickness	1.0-1.5 mm, 0.040-0.060"	1.5-2.0 mm 0.060-0.080"	2.0-2.5 mm 0.080-0.100"	2.5-3.0 mm 0.100-0.120"
4-bladed round	92 30730	92 30731	92 30732	72 00029
2-bladed round	92 30790	92 30791	92 30792	72 00032
Rectangular	92 30830	92 30831	92 30832	92 30833
Aluminum, brittle material				
4-bladed round	92 30735	92 30736	92 30737	72 00041
2-bladed round	92 30795	92 30796	92 30797	72 00044
Rectangular	92 30830	92 30831	92 30832	92 30833

**ATTEXOR Tools S.A.**  
 Chemin du Chêne 7  
 CH-1020 Renens/Lausanne  
 Switzerland  
 Phone: +41 21 691 13 80  
 Fax: +41 21 691 13 89  
 www.attexortools.com  
 info@attexortools.com

**ATTEXOR, Inc.**  
 90 Carando Drive  
 Springfield, MA 01104  
 United States  
 Phone: 413-746-0222  
 Fax: 413-746-6341  
 www.attexorinc.com  
 info@attexorinc.com

This document copyright  
 © 2005-2009 by  
 ATTEXOR Tools S.A.  
 All rights reserved  
 Printed matter No 55 02002  
 Nov-09

**Distributor**